

CURRENT REVISION LEVEL	
B	01-04-19 UPDATE MATERIAL RANGE TO BE 1018-1022
C	09-25-19 ADD "RU" LOGO

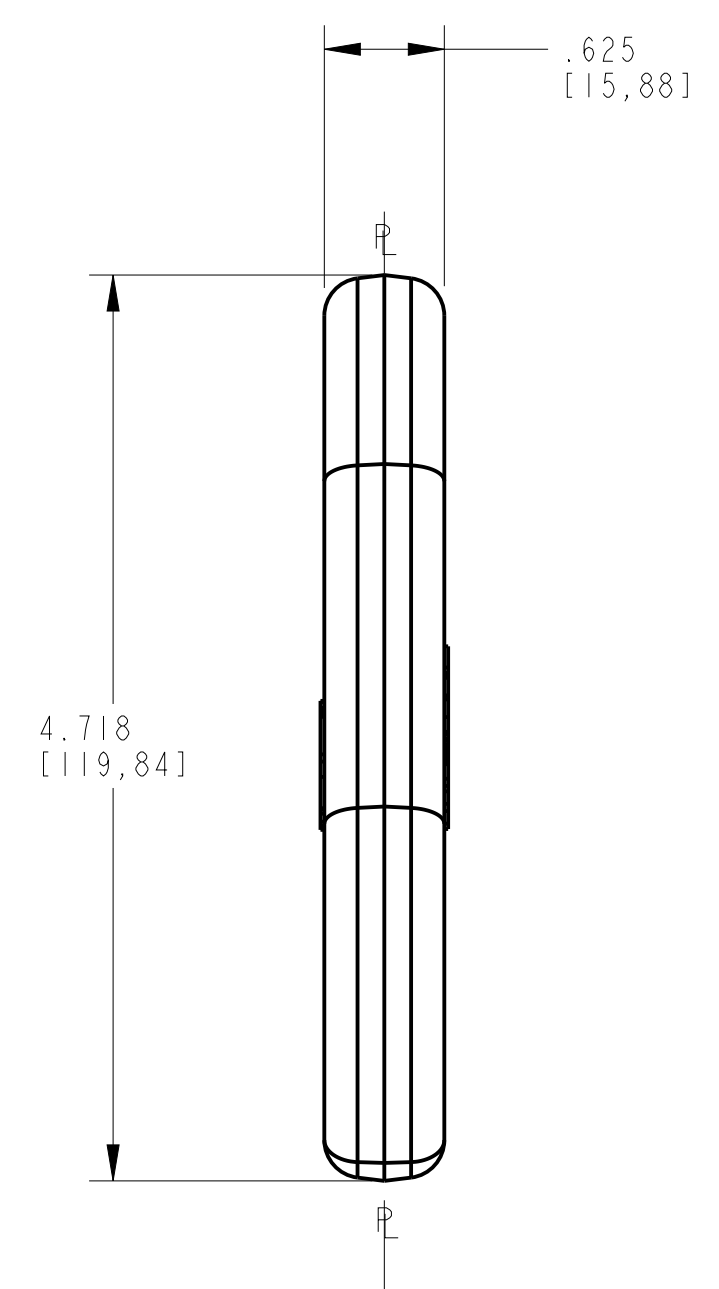

FORGE VIEWS

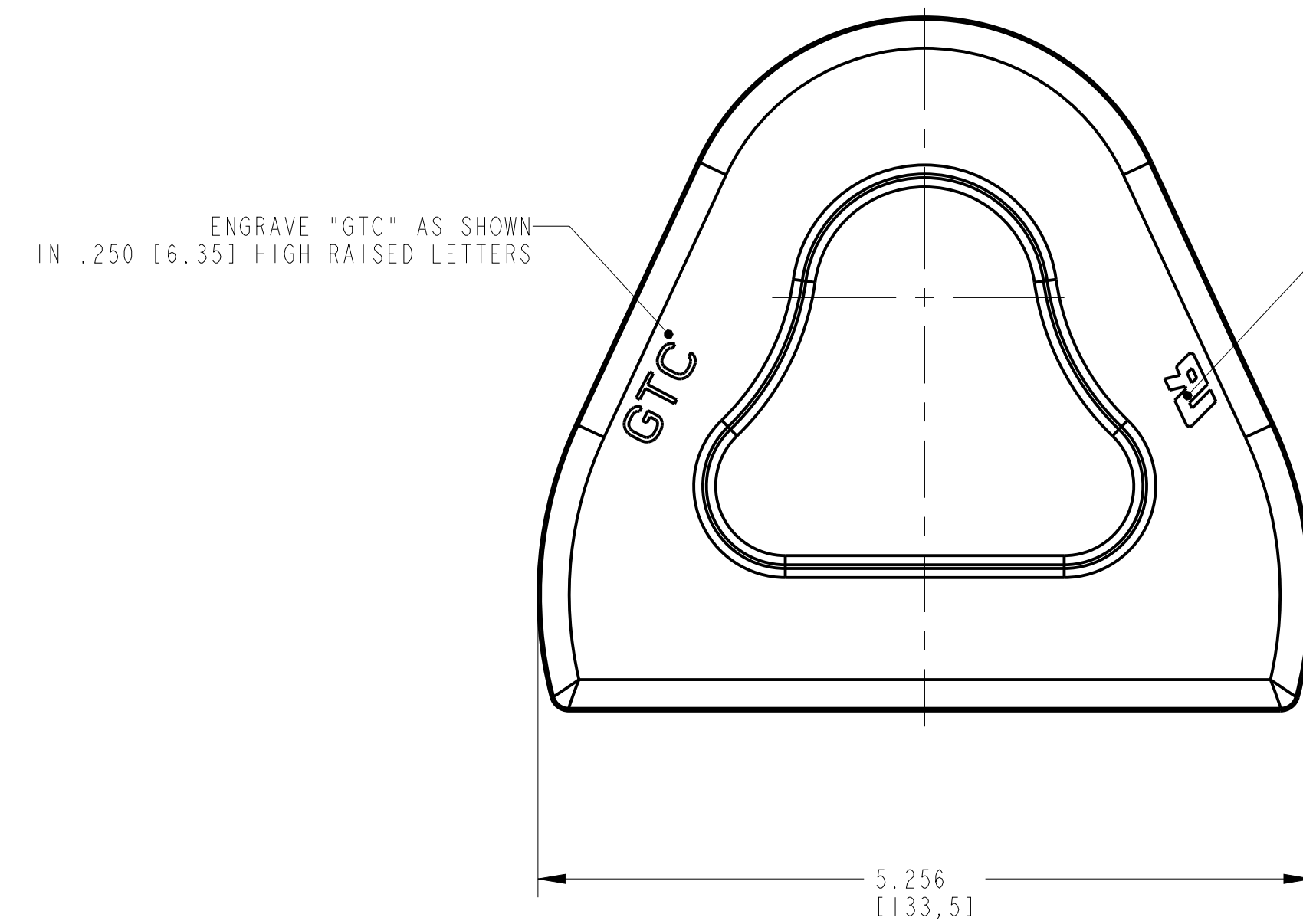
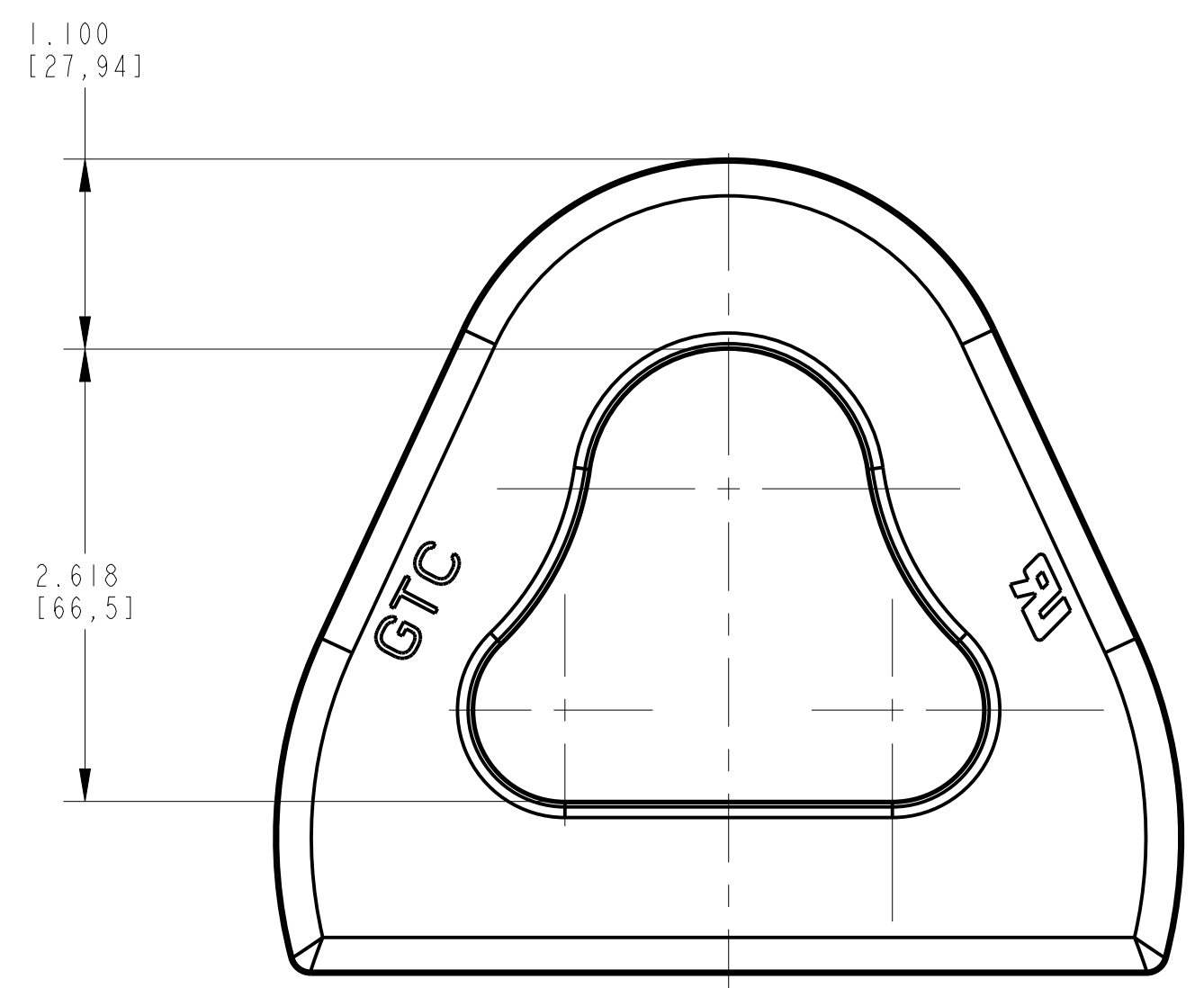
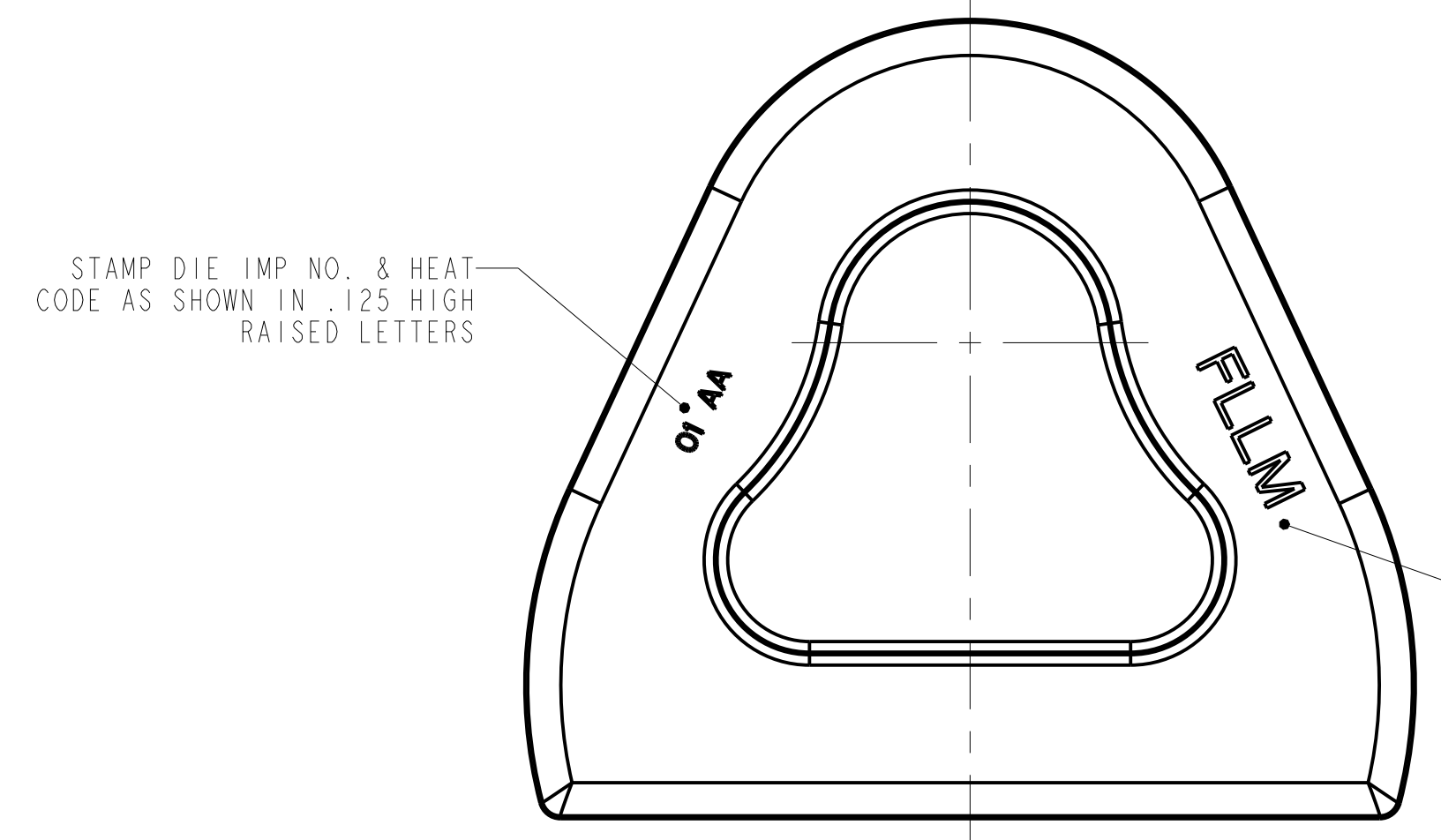

PUNCH VIEWS

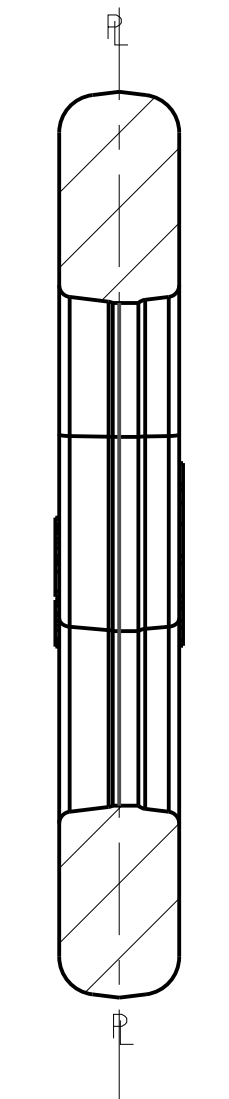

NOTES: (UNLESS OTHERWISE SPECIFIED)

-ACTUAL MISMATCH $\pm .015$ [.38] MAX.
 T.I.R. $\pm .030$ [.76]

-FLASH EXTENSION $\pm .015$ [.38] MAX.

-FORGING TOLERANCES:
 GENERAL TOLERANCE $\pm .030$ [.8]
 DRAFT: $7^{\circ} \pm 2^{\circ}$

-MATERIAL: 1018-1022 MOD (MUST COMPLY WITH ASTM A105 CHEMICAL REQUIREMENTS, INCLUDING S4 SUPPLEMENT FOR CARBON EQUIVALENCE)

TOLERANCES: SEE NOTES	GLOBAL TANK COMPONENTS	
	PART NUMBER: FLLM PART NAME: LIFTING LUG MATERIAL: SEE NOTES	
	DRAWN: 12-07-18 DRAWN BY: DWE	