

CURRENT REVISION LEVEL	
B	01-04-19 UPDATE MATERIAL RANGE TO BE 1018-1022
C	09-24-19 ADD "RU" LOGO

ENGRAVE "GTC" AS SHOWN
IN .188 [4.8] HIGH RAISED
LETTERS

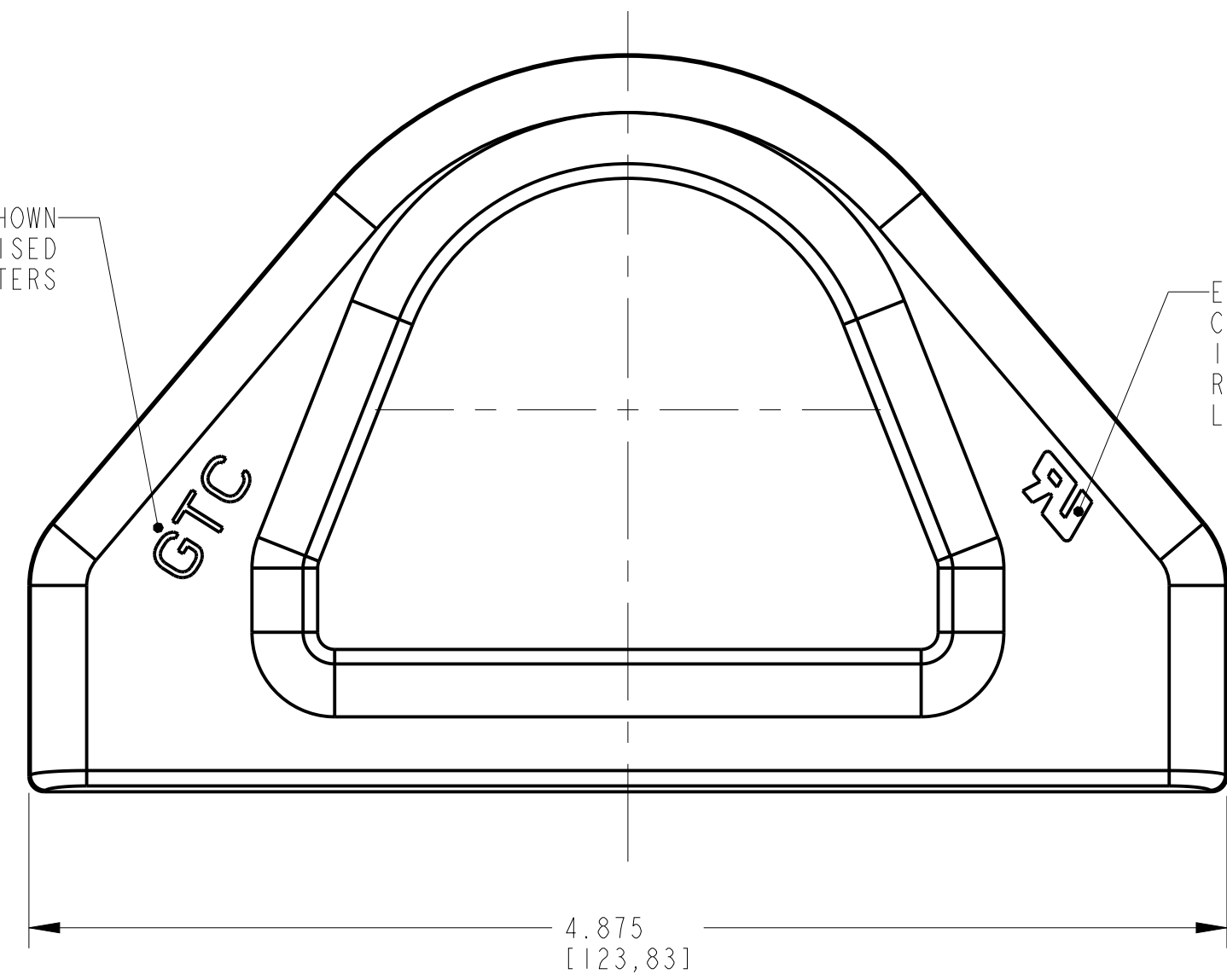

ENGRAVE RECOGNIZED
COMPONENT MARK AS SHOWN
IN .188 [4.8] HIGH LETTERS,
RAISED .020 [.5] PER UNDERWRITERS
LABORATORIES INC. FORM 200-1950

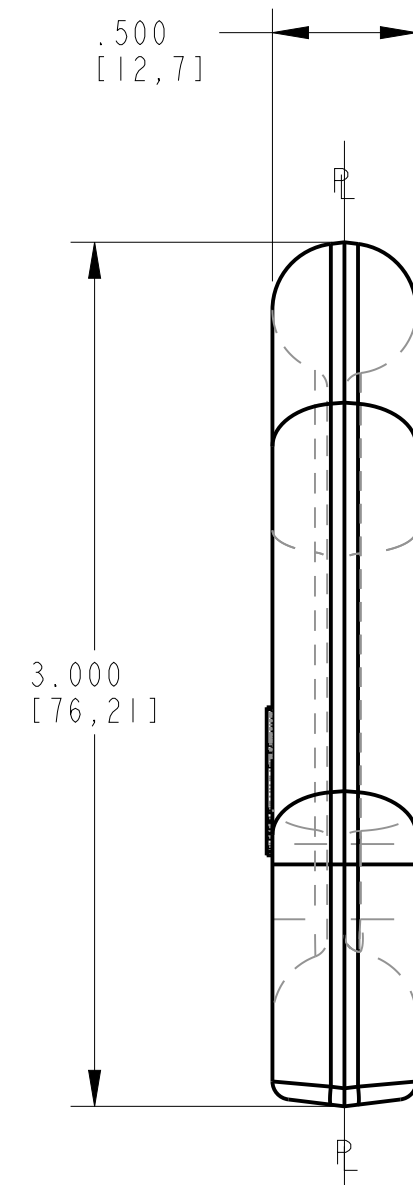

STAMP DIE IMP. NO AND
HEAT AS SHOWN IN .125 [3.2] HIGH
RAISED LETTERS

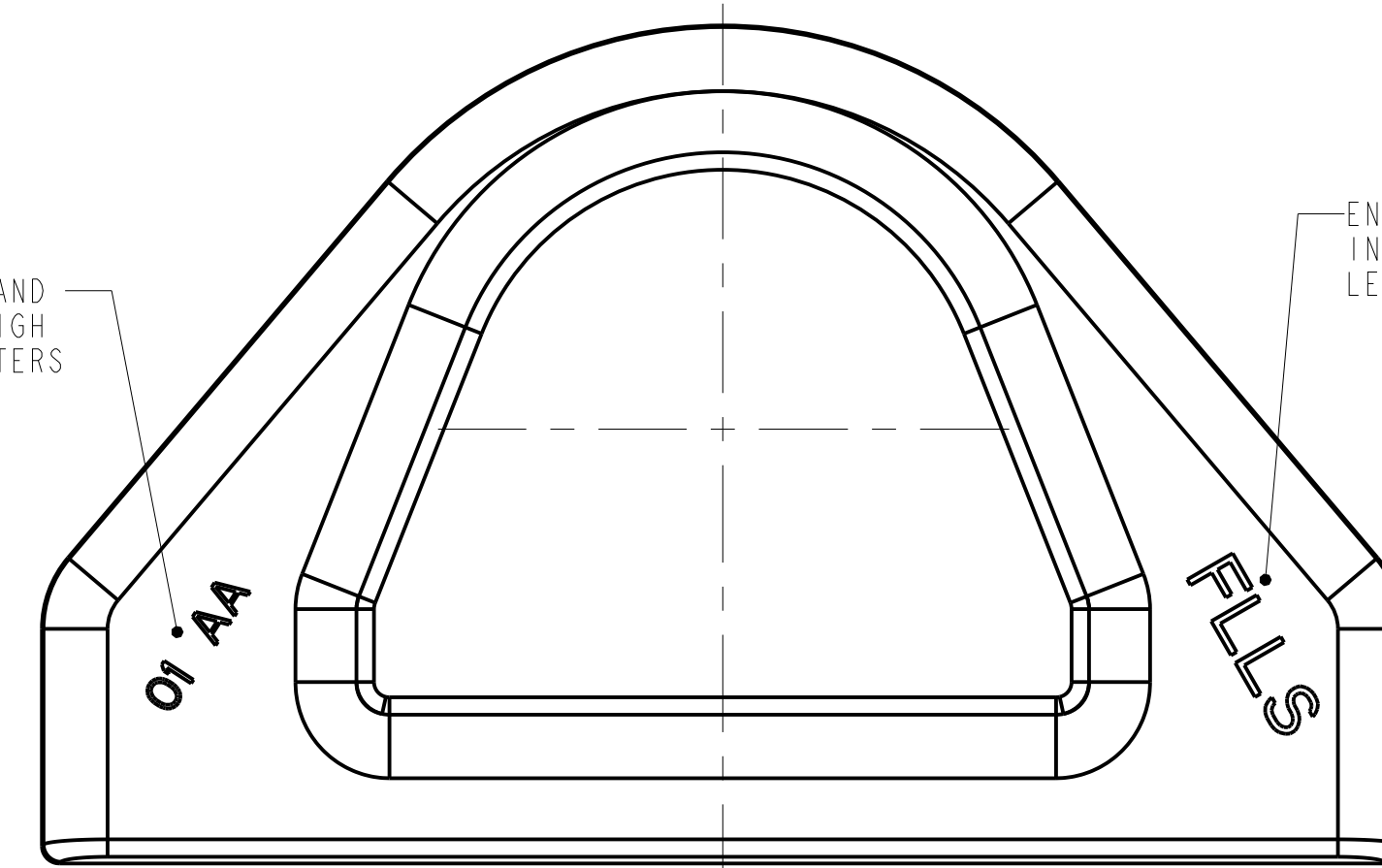

ENGRAVE "FLLS" AS SHOWN
IN .188 [4.8] HIGH RAISED
LETTERS

FORGE VIEWS

NOTES: (UNLESS OTHERWISE SPECIFIED)

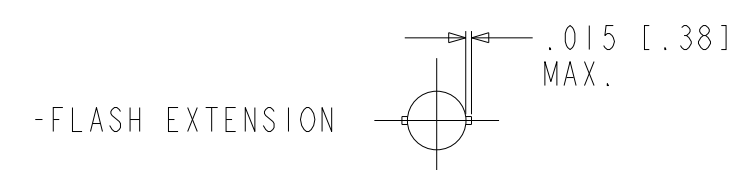
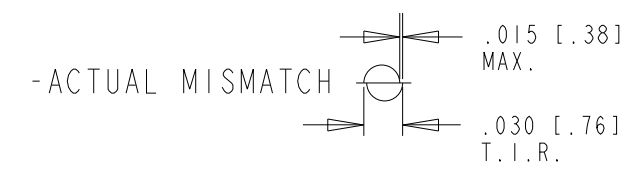

-FORGING TOLERANCES:
GENERAL TOLERANCE $\pm .030$ [.8]
DRAFT: $7^{\circ} \pm 2^{\circ}$

-MATERIAL: 1018-1022 MOD (MUST COMPLY WITH ASTM A105 CHEMICAL REQUIREMENTS,
INCLUDING S4 SUPPLEMENT FOR CARBON EQUIVALENCE)

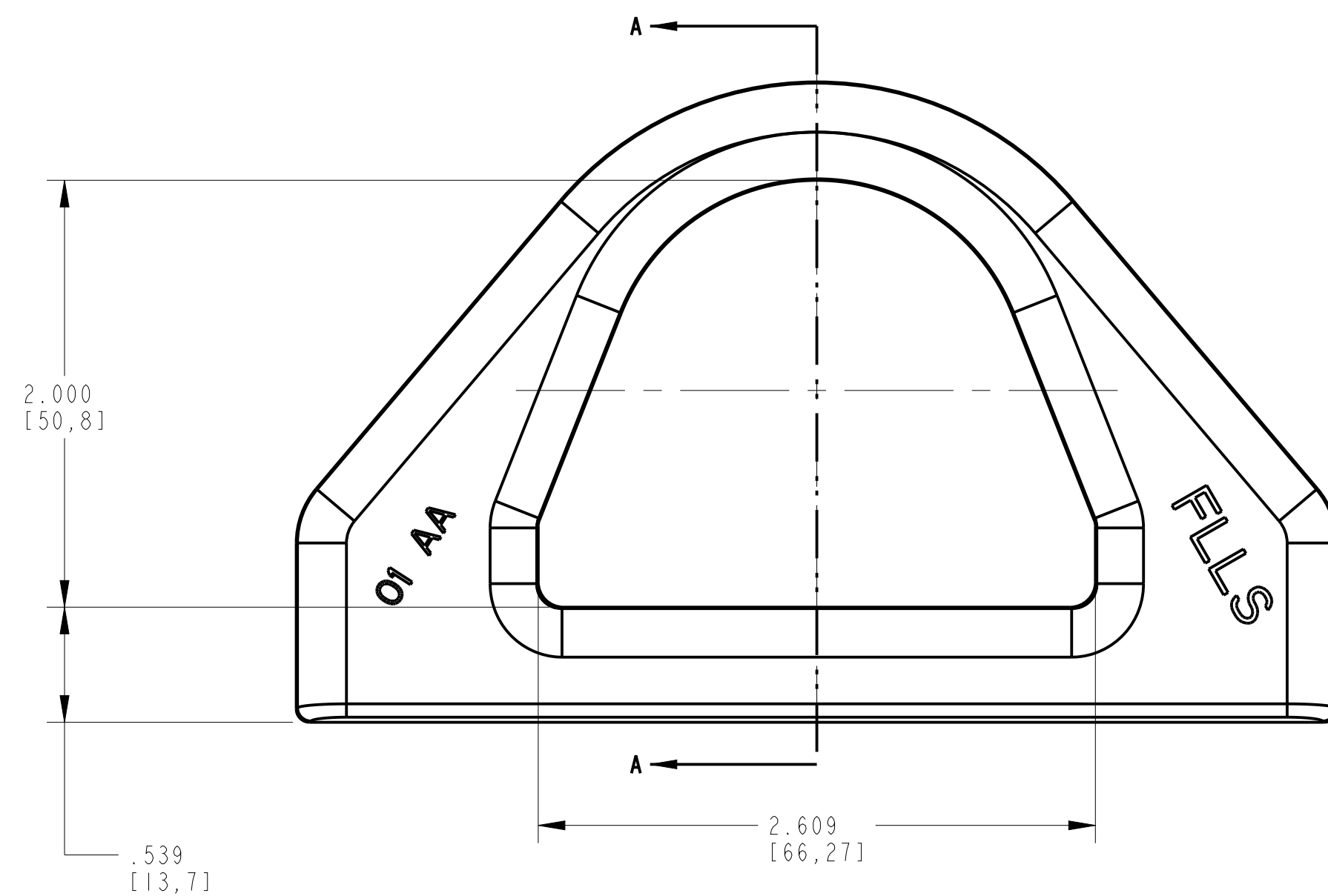

PUNCH VIEWS

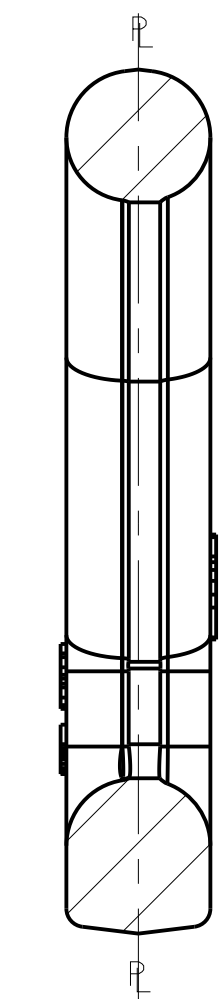

SECTION A-A

TOLERANCES: SEE NOTES	GLOBAL TANK COMPONENTS	
	PART NUMBER: FLLS PART NAME: LIFTING LUG MATERIAL: SEE NOTES	
	DRAWN: 12-05-18 DRAWN BY: DWE	